

# Manta<sup>®</sup>

## High Capacity Digital Camera & Laser Sorter

### Features & Benefits

- Multiple camera & laser configurations to match product requirements
- Fluo and IR Laser in-air sorting
- High Resolution Vis/IR, UV or Tri-chromatic camera options
- HID, UV, & LED lighting options
- Simple, user-friendly operation, cleaning and maintenance
- Easy adjustment for product change over
- Information analytics for integration with process controls
- Wet or dry products

### Precise Defect Identification

The Manta sorting platforms are characterized by exceptional color, shape, size and texture recognition. High resolution Vis/IR, Tri-chromatic, or UV cameras and IR or Fluo lasers ensure even the subtlest defects are identified and targeted for removal increasing quality.

### Precise Removal of Defects and Foreign Material

The intelligent ejection system features precision pneumatic-based valves with exceptional response time for pinpoint accuracy. Unparalleled yield improvement can be achieved with the optional three-way sorting.

### Intelligent Sorting

Advanced object-based image processing allows FMAAlert™ to track foreign material providing you with a digital record. Custom algorithms determine shape, length, width, curvature, symmetry, circularity and other special characteristics improving quality.

### Real-Time Condition Analysis and Remote Support

Unique to the industry, RemoteMD™ proactively monitors the sorter conditions and alerts plant personnel to changes that impact performance, reliability, and maintenance. The web-based diagnostics ensure the highest sorter availability and productivity.



Manta 2000

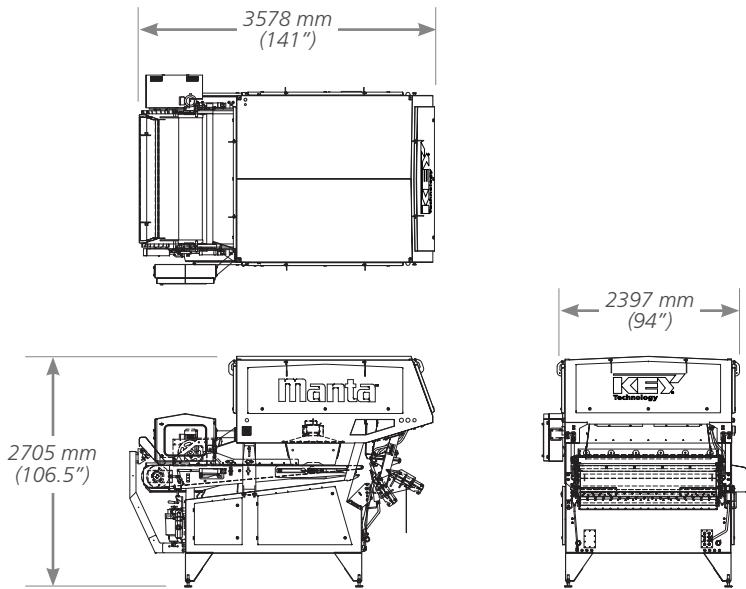

Manta 1600

### Typical Applications

Green beans (cut, whole), peas, cut corn, carrots,  
Potatoes (frozen and strips, chips/crisps), wet or dry products.

### Sorting Excellence

A major US vegetable processor runs full factory line-flow of cut green beans through Manta at over 40,000lbs/hour and successfully removes a specific defect that other sorters could not detect.

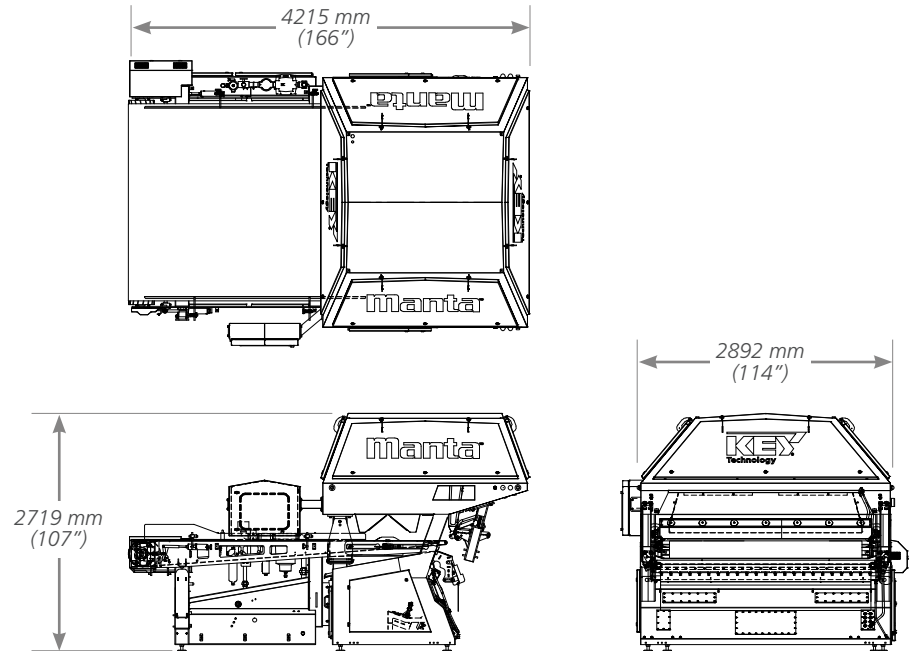

Manta 2000

### Results

Increased yields, reduced labor, increased profit

### Capacity

Manta 1600 up to 15metric tons (33,000lbs)/hour\*

Manta 2000 up to 20 metric tons (44,000lbs)/hour\*

*\*Depending on product and defect load*